

ROD LINKAGE #SW280-R

SHIFTWORKS® uses 5/16 inch linkage components with **left and right hand threaded ends**. The value of using this combination is that the final adjustment can be made by simply turning the rod clockwise or counter clockwise with the linkage installed to achieve the best fit. Many combinations of rod length are possible by shortening and combining the linkages included. **Use the jam nuts to tighten the linkage.** The shifter is designed to allow a very low profile by simply adjusting the legs to suit. This is a universal shifter applicable to many applications but specific to none.

EXPLODED VIEW

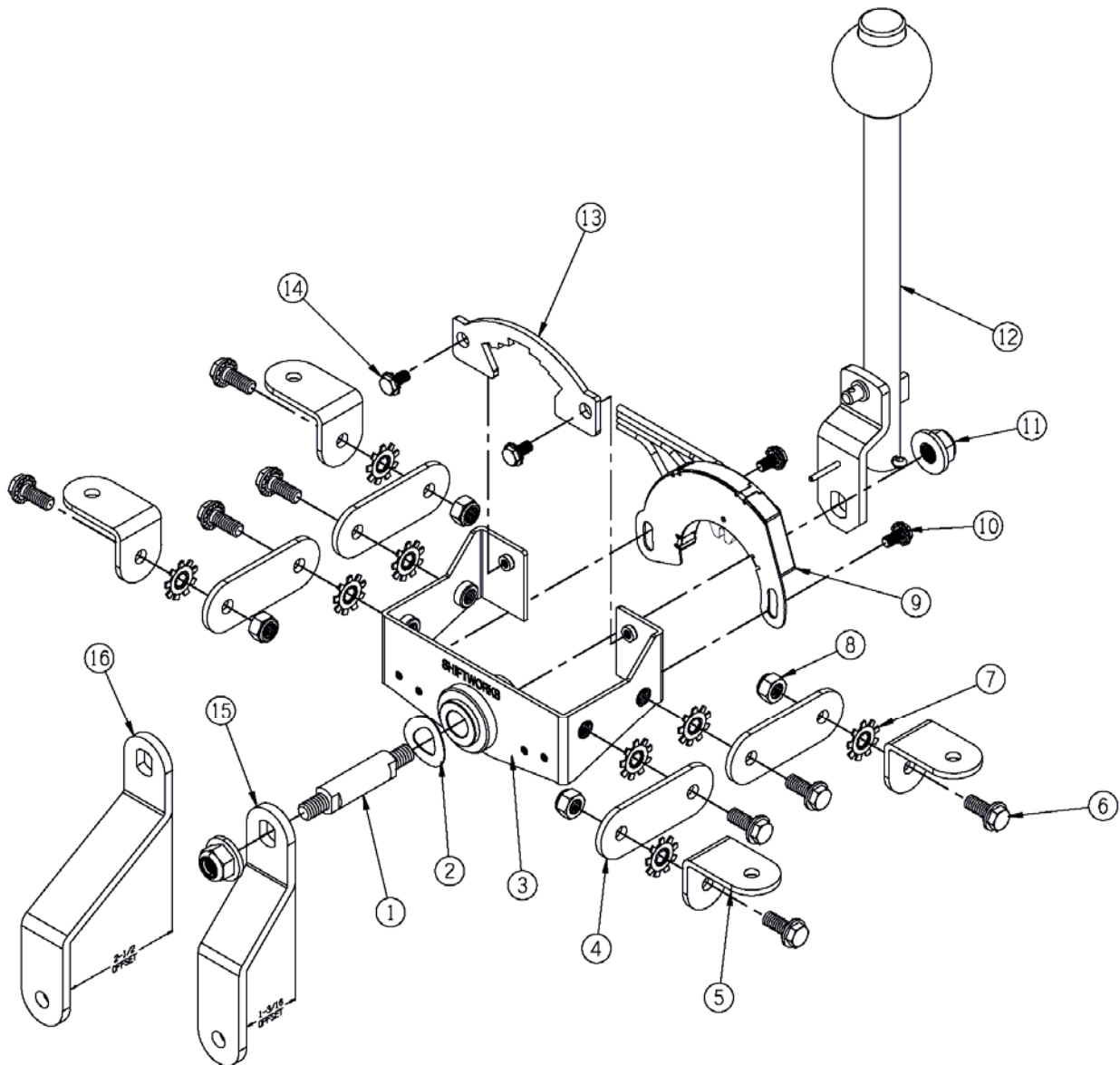

ROD LINKAGE TYPICAL INSTALLATION

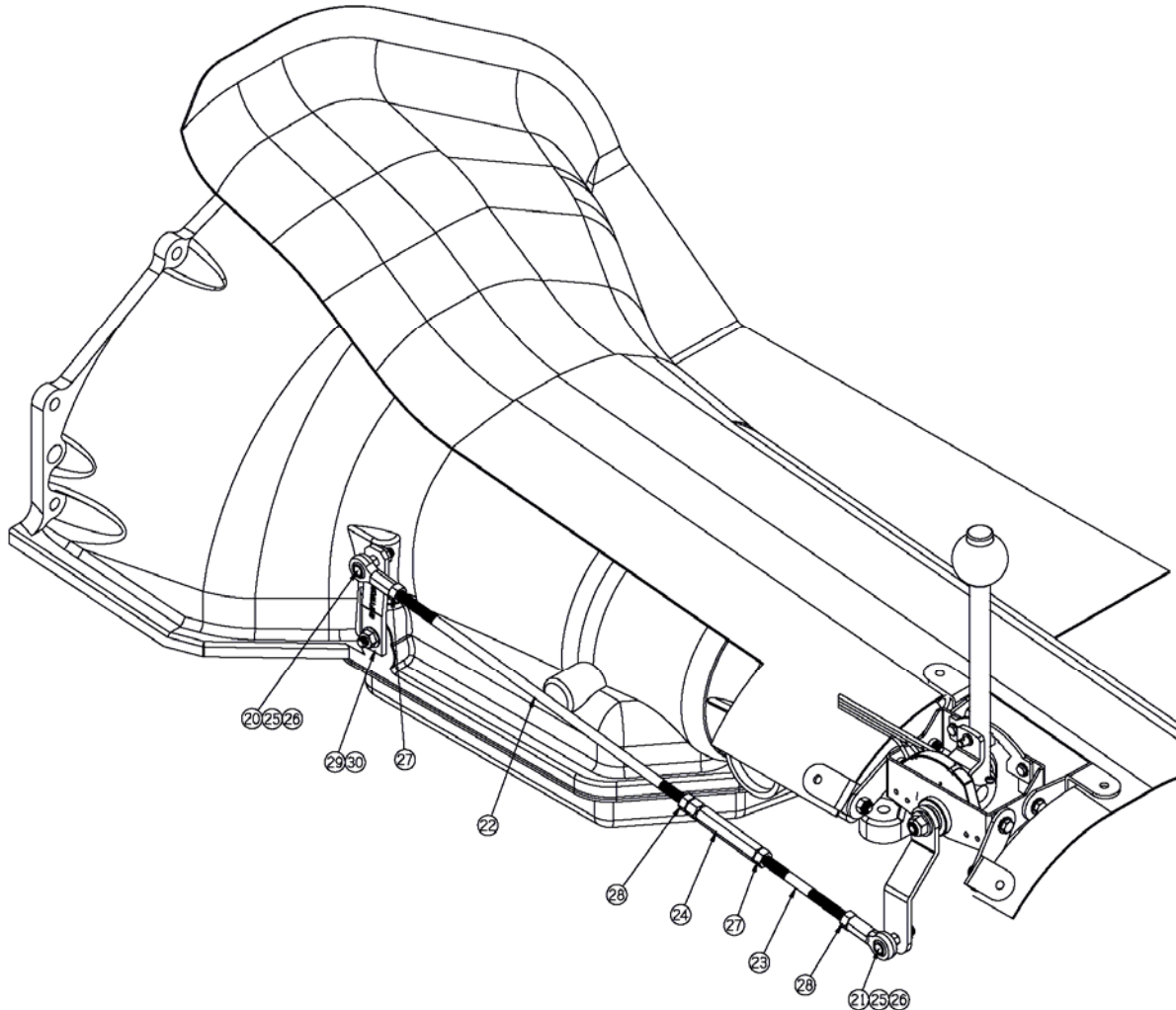

- Attach universal mounting legs/brackets to the shifter base. Use star washers between mating surfaces.
- Determine location of shifter and height required to clear console. Shifter can be lowered to beneath the floor if necessary. See illustration above.
- Adjust legs height and position. Mark and re-check.
- Mark and create hole in floor as necessary.
- Remove heavy washer on outside of shifter base and replace with offset shift arm.
- Put transmission control arm on pointing up, with SHIFWORKS® name facing out. Use upper hole for the longer (black) shift arm and lower hole for the shorter (gold) shift arm attached to the shifter. The longer (black) arm has greater mechanical advantage, but the shorter (gold) arm may help avoid conflicts
- Use linkage components as required. Not all may be necessary. Components are RIGHT and LEFT hand threads.
- Adjust detent stops by spinning rod linkage.

- Neutral Safety/Back-up Switch. Purple wires are for Neutral safety and Green and Pink wires are for back-up lights. Adjust for Back-up lights first, and then rotate switch to suit. If pre-installed, switch is pre-set.

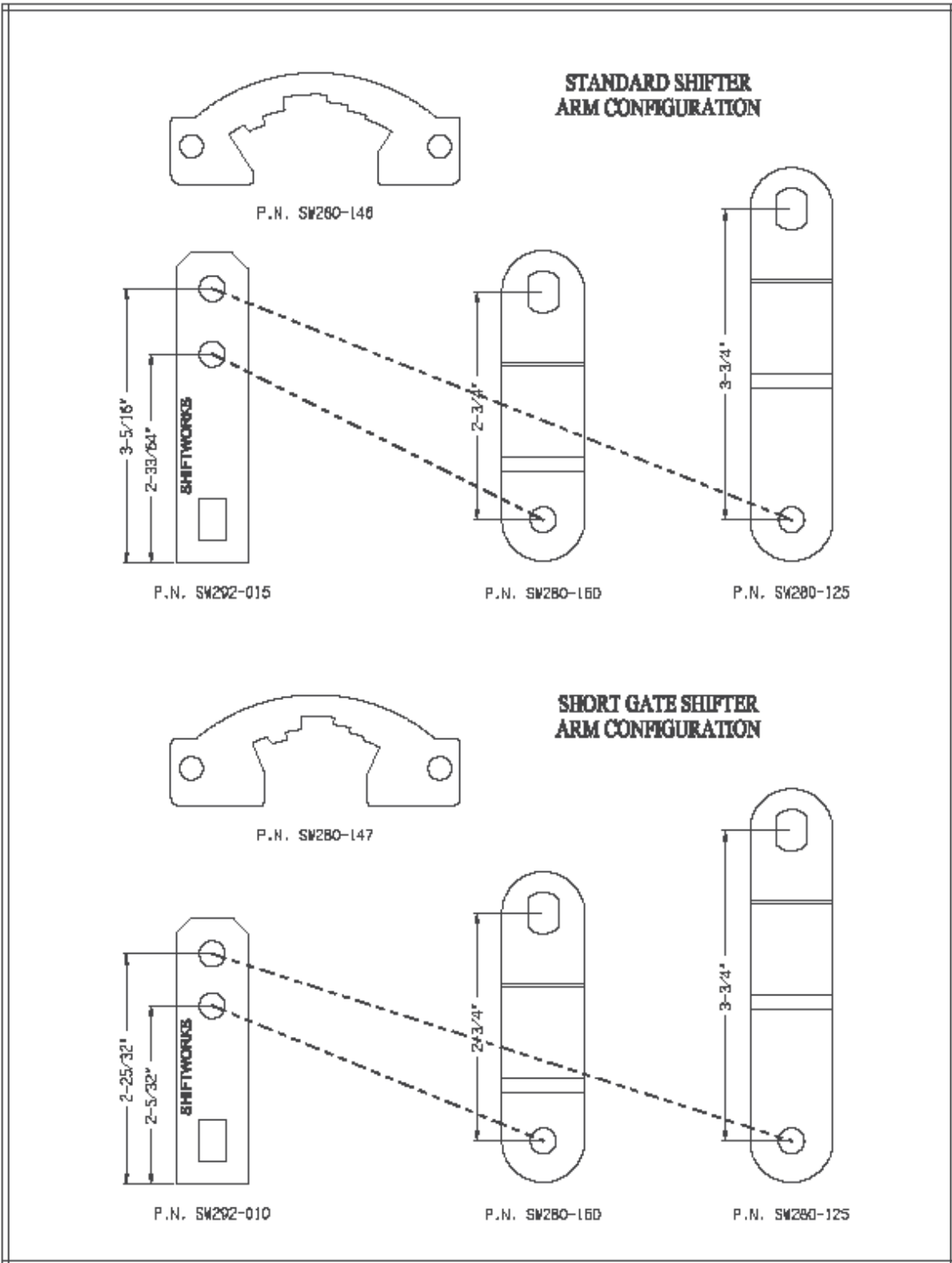

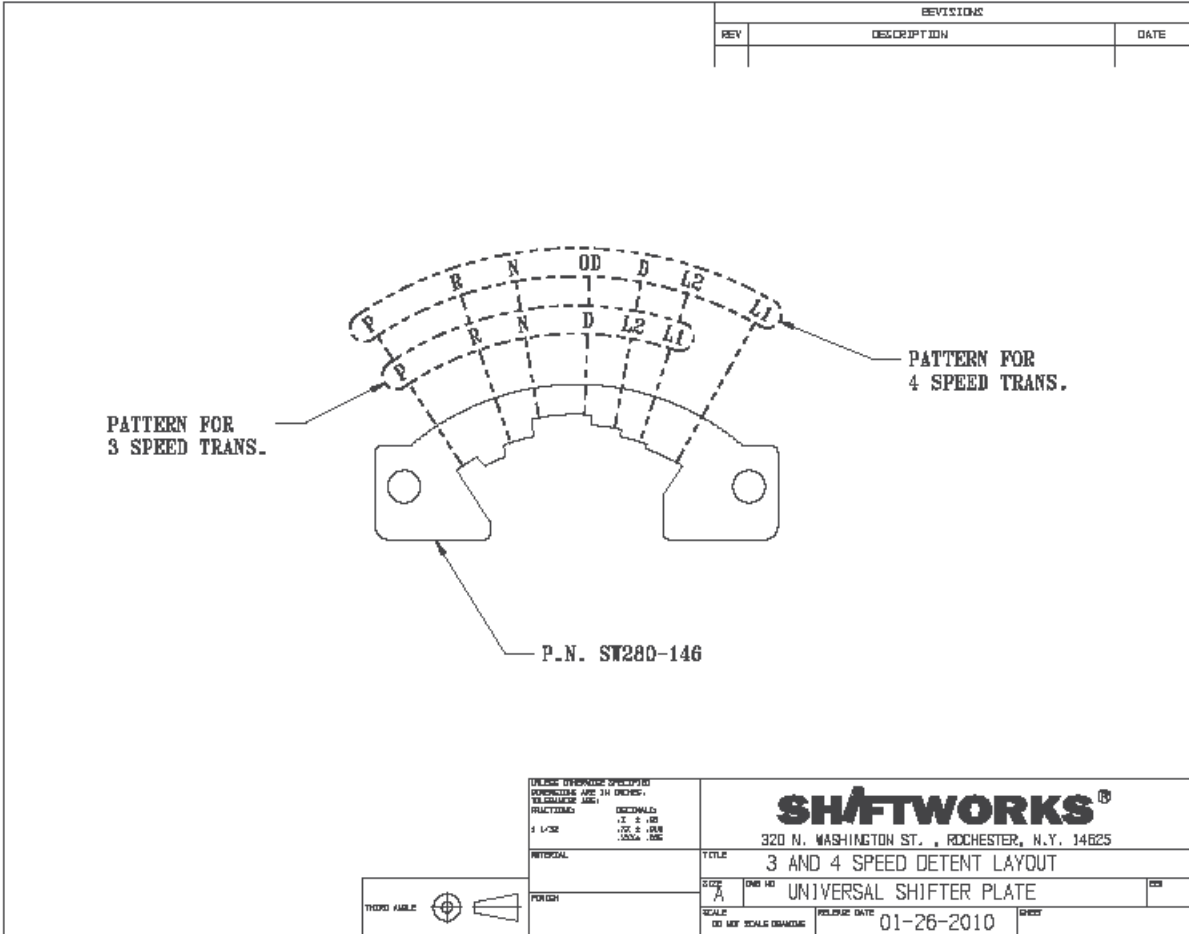

(UNLESS OTHERWISE SPECIFIED)
 DIMENSIONS ARE IN INCHES
 FRACTIONS ARE:
 FRACTIONS DECIMALS
 1/16 0.0625
 1/8 0.125
 1/4 0.25
 3/8 0.375
 1/2 0.5
 5/8 0.625
 3/4 0.75
 7/8 0.875
 1 1.0

SHIFTWORKS®

320 N. WASHINGTON ST., ROCHESTER, N.Y. 14625

MATERIAL		TITLE	
		3 AND 4 SPEED DETENT LAYOUT	
FINISH		SIZE	DRW NO
		A	UNIVERSAL SHIFTER PLATE
		SCALE	RELEASE DATE
		DO NOT SCALE DIMENSIONS	01-26-2010